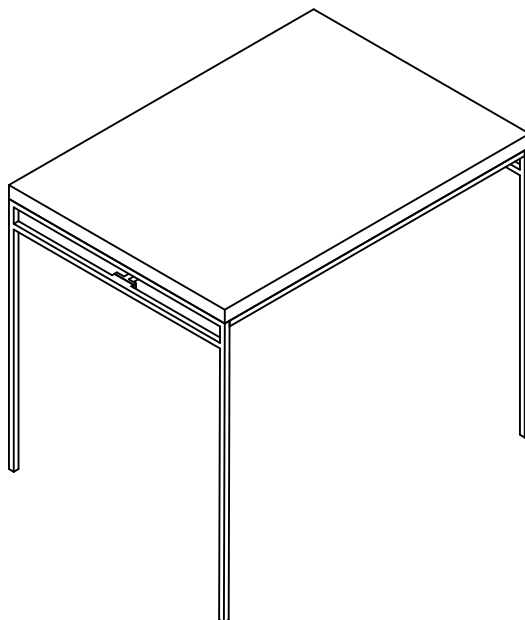
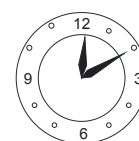

TABLE DE BAR YPSTER / BAR TABLE YPSTER / BARTISCH YPSTER / MESA DE BAR YPSTER / TAVOLO DA BAR YPSTER REF : 46019

Notice de montage / Assembling Instruction / Instrucciones de montaje /
Istruzioni di montaggio



< 70 Kg



10'

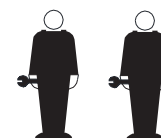

FRANÇAIS	ENGLISH
<ul style="list-style-type: none"> > Consacrez quelques minutes à la lecture de cette notice de montage avant de suivre pas-à-pas les différentes étapes d'assemblage > Vérifiez que vous disposez de toutes les pièces et accessoires nécessaires au montage de votre meuble avant de jeter tout emballage > Effectuez votre montage sur une surface plane > Ne serrez pas les vis au maximum avant la fin du montage > Jetez les pièces supplémentaires et gardez les hors de portée des enfants 	<ul style="list-style-type: none"> > We suggest you spend a short time reading through this leaflet and follow the simple step-by-step assembly instructions. > Do not discard any of the packaging until you have checked that you have all the parts and the pack of fittings. > Assemble this product on a flat surface. > Assemble all parts loosely before tightening any bolts. > Discard all extra fittings and keep fittings out of reach of children.
ESPAÑOL	ITALIANO
<ul style="list-style-type: none"> > Dedique unos minutos a la lectura de estas instrucciones para seguir paso a paso las etapas de montaje. > Compruebe que dispone de todas las piezas y accesorios necesarios al montaje antes de tirar los embalajes > Efectúe el montaje sobre una superficie plana > No apriete los tornillos al máximo hasta el final del montaje > Lanzar piezas adicionales y mantenerlos fuera del alcance de los niños 	<ul style="list-style-type: none"> > Leggere attentamente le istruzioni di montaggio prima di cominciare > Prima di buttare il cartone d'imballo verificare scrupolosamente che nessun elemento nè accessorio sia mancante > Effettuare il montaggio su una superficie piana > Non serrare le viti al massimo prima della fine del montaggio > Buttare i pezzi supplementari e tenerli fuori portata dei bambini

Retrouver l'intégralité de nos collections sur www.miliboo.com. Pour plus d'information veuillez nous contacter au 08 05 14 44 44 (numéro vert) ou par email info@miliboo.com

Find all our collections on www.miliboo.co.uk. For more information please contact us at 0203 355 98 09 (toll free) or by email at info@miliboo.com

Vea toda nuestra colección en www.miliboo.es. Para más detalle, nos puede llamar al 933 96 87 86 o mandar un correo electrónico a miliboo@miliboo.es

Ritrovi la totalità della nostra collezione su www.miliboo.it. Per ulteriori informazioni contatti lo 06 99 26 81 42 o invii una mail a info@miliboo.it

PIECES / PARTS LIST / PARTES / PEZZI

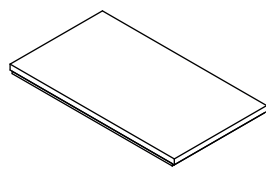

A x 1



B x 2

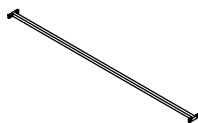

C x 1

FIXATION / FASTENINGS / FIJACIÓN / FISSAZIONE



F x 4

M6 X 50 mm



G x 4

M6 X 25 mm



H x 1

